



# WB5N Series 5 Gallon Water Boiler



Style and color varies - Model WB5N shown

## READ AND SAVE THESE INSTRUCTIONS

**NOTICE TO INSTALLER:** Please leave this booklet with the machine.

Key Features/Specifications/System Requirements..... FS55

Important Safeguards..... IS2

Installation Instructions (General).....II20

Installation Instructions (Water Supply, Electrical) .....II27

Operating Instructions .....OI40

Programming Guide ..... PG16

Cleaning Instructions..... CI16

Rough-In Drawing..... RD61

Illustrated Parts/Recommended Parts (Main Chassis)..... IP102

Illustrated Parts/Recommended Parts (Tank Assembly)..... IP103

Electrical Schematic (Domestic)..... ES97

Electrical Schematic (Export) ..... ES99

Troubleshooting Guide .....TG32

Error Codes .....EC9

Product Warranty.....PW1

**Contact Information**

**Wilbur Curtis Co., Inc.**

6913 Acco Street | Montebello, CA 90640 US  
 Phone: 323-837-2300 | Toll Free: 800-421-6150  
 Email: [cstrassistance@wilburcurtis.com](mailto:cstrassistance@wilburcurtis.com) | Web: [www.wilburcurtis.com](http://www.wilburcurtis.com)

For the latest specifications and information go to [www.wilburcurtis.com](http://www.wilburcurtis.com)  
 Toll Free: 800-995-0417 | Monday - Friday 5:30 A.M. - 4:00 P.M. PT  
 Email: [techsupport@wilburcurtis.com](mailto:techsupport@wilburcurtis.com)

Due to continued product improvement, the products illustrated/photographed in this guide may vary slightly from the actual product.

**Key Features**

- G3 Digital Control Module – Provides precise control of temperature.
- Agitation Pump – On-demand aeration improves tea extraction and food flavor.
- Easy-To-Operate – Simple graphics for all operating functions and ready lights.
- Energy Savings Mode – 4 hours after last dispense, tank will maintain temperature of 140°.
- Automatic Refill System – For hot water anytime.

**Specifications (Selected Models)**

**Electrical Supply Requirements**

MODEL #	DESCRIPTION	PHASE	VOLTS	AMPS	HEATING CONFIG	WIRE	WATTS	HERTZ	GAL/HR
WB5N	5.0 Gallon - red	1 PH	120/220 V	12.5/22.7 A	2 X 2500 W	2W/3W + G	1500/5000 W	50/60 Hz	4.5/15.0
WB5NL	5.0 Gallon - red, low faucet	1 PH	120/220 V	12.5/22.7 A	2 X 2500 W	2W/3W + G	1500/5000 W	50/60 Hz	4.5/15.0
WB5NB	5.0 Gallon - black	1 PH	120/220 V	12.5/22.7 A	2 X 2500 W	2W/3W + G	1500/5000 W	50/60 Hz	4.5/15.0
WB5NLB	5.0 Gallon - black, low faucet	1 PH	120/220 V	12.5/22.7 A	2 X 2500 W	2W/3W + G	1500/5000 W	50/60 Hz	4.5/15.0
<b>Export</b>									
WB5N30	5.0 Gallon	1 PH	230 V	23.9 A	2 X 2500 W	2W + G	5500 W	50/60 Hz	15.0

**Dimensions**

**Water Supply Requirements**

MODEL #	HEIGHT	WIDTH	DEPTH	SHIP WEIGHT	SHIP CUBE	WATER CONNECTOR	WATER PRESSURE	MIN. FLOW RATE
WB5N	25.75"	7.50"	25.55"	42.0 lbs	5.90 cu ft	1/4" flare	20 - 90 psi	1.0 gpm
WB5NL	25.75"	7.50"	25.55"	42.0 lbs	5.90 cu ft	1/4" flare	20 - 90 psi	1.0 gpm
WB5NB	25.75"	7.50"	25.55"	42.0 lbs	5.90 cu ft	1/4" flare	20 - 90 psi	1.0 gpm
WB5NLB	25.75"	7.50"	25.55"	42.0 lbs	5.90 cu ft	1/4" flare	20 - 90 psi	1.0 gpm
<b>Export</b>								
WB5N30	25.75"	7.50"	25.55"	42.0 lbs	5.90 cu ft	1/4" flare	20 - 90 psi	1.0 gpm

Following are the factory default settings for the water boiler:

- Temperature = 204°F
- Temperature scale = °F
- Energy Save Mode = Off

**Symbols**



This is the safety alert symbol. It is used to alert you to potential physical injury hazards. Obey all safety messages that follow this symbol to avoid possible injury or death.



**DANGER** - Indicates a hazardous situation which, if not avoided, will result in death or serious injury.



**WARNING** - Indicates a hazardous situation which, if not avoided, could result in death or serious injury.



**CAUTION** - Indicates a hazardous situation which, if not avoided, could result in minor or moderate injury.



**NOTICE** - Indicates a situation which, if not avoided, could result in property damage.



**IMPORTANT** - Provides information and tips for proper operation.



**SANITATION REQUIREMENTS**

**Important Safeguards/Conventions**



**WARNING:**

- Make sure that this appliance is installed and grounded according to the INSTALLATION INSTRUCTIONS by qualified personnel before attempting to use it. Failure to follow the INSTALLATION INSTRUCTIONS could result in personal injury or void the warranty.
- This appliance is designed for commercial use. Any service other than cleaning and preventive maintenance should be performed by an authorized Wilbur Curtis service technician.
- To reduce the risk of fire or electric shock, DO NOT open the service panels. There are no user serviceable parts inside.
- Keep hands, arms and other items away from hot surfaces of the unit during operation.
- Clean the appliance and any dispensers completely before using them for the first time as according to the CLEANING INSTRUCTIONS. Clean them regularly as instructed in the CLEANING INSTRUCTIONS.
- Use this appliance only for its intended use, brewing/dispensing hot and/or cold beverages/water.
- This appliance is not intended for use by persons (including children) with reduced physical, sensory or mental capabilities or lack of experience and knowledge, unless they have been given supervision or instruction concerning use of the appliance by a person responsible for their safety.
- Children should be supervised to ensure that they do not play with the appliance.
- Avoid spillage onto the power (mains) connector.

## CE Requirements

- This appliance must be installed in locations where it can be overseen by trained personnel.
- For proper operation, this appliance must be installed where the temperature is between 5°C to 35°C.
- Appliance shall not be tilted more than 10° for safe operation.
- An electrician must provide electrical service as specified in conformance with all local and national codes. For safe use, an all-pole disconnection must be incorporated into the fixed wiring in accordance with the wiring rules outlined in clause 7.12.2 of IEC 6.335-1 for meeting the minimum electrical safety of this standard.
- This appliance must not be cleaned by water jet.
- This appliance can be used by persons aged from 18 years and above if they have been given supervision or instruction concerning use of the appliance in a safe way and if they understand the hazards involved.
- Keep the appliance and its cord out of reach of children aged less than 18 years.
- Appliances can be used by persons 18 years and above with reduced physical, sensory or mental capabilities or lack of experience and knowledge if they have been given supervision or instruction concerning use of the appliance in a safe way and understand the hazards involved.
- Children under the age of 18 years should be supervised to ensure they do not play with the appliance.
- If the power cord is ever damaged, it must be replaced by the manufacturer or authorized service personnel with a special cord available from the manufacturer or its authorized service personnel in order to avoid a hazard.
- Machine must not be immersed for cleaning.
- Cleaning and user maintenance shall not be made by children unless they are older than 18 years and supervised.
- This appliance is intended to be used in household and similar applications such as:
  - staff kitchen areas in shops, offices and other working environments;
  - by clients in hotels, motels and other residential type environments;
  - bed and breakfast type environments.
- This appliance not intended to be used in applications such as:
  - farm houses
- Access to the service areas permitted by Authorized Service personnel only.
- The A-Weighted sound pressure level is below 70 dBA.



**WARNING:** Installation is to be performed only by a qualified installer.



**WARNING:** Improper electrical connection may result in an electric shock hazard. This brewer must be properly grounded.



**NOTICE:** DO NOT connect this appliance to a hot water supply. The water inlet valve is not rated for hot water. Do not exceed the maximum water pressure stated in the **SPECIFICATIONS** section.



**IMPORTANT:** Observe all governing codes and ordinances.

## Installation Instructions

### Installation Requirements

- A secure surface capable of supporting the weight of the appliance.
- For units without an attached cord set: Appropriately sized, UL listed, grounding type power cable to meet the electrical specifications for the appliance. If you have questions about the correct cable size and length, consult a qualified installer. If the unit will be hard wired to a junction box, the power cable must be long enough so that it can be moved for cleaning underneath.
- A grounded electrical connection to an electrical circuit that meets the electrical specifications of the appliance (see **SPECIFICATIONS**). The circuit must be protected by the appropriate sized circuit breaker. If you are not certain that the existing circuit meets the requirements for your unit, consult a licensed electrician.
- A water filtration system is required to maintain trouble-free operation. Wilbur Curtis Co., Inc. recommends a Wilbur Curtis approved water filter. Visit [www.wilburcurtis.com](http://www.wilburcurtis.com) to see the full line of Wilbur Curtis approved water filters.
- Potable water supply line connection from the water filter capable of supplying the minimum flow rate required by the specifications. The water supply line must be able to connect to the flare fitting on the back of the brewer. See the **SPECIFICATIONS** section for the correct size. The water line should also be capable of being controlled by a shut off valve. Do not connect the water line to a saddle valve.



NSF International requires the following water connection:

- 1 A quick disconnect or additional coiled tubing (at least two times the depth of the brewer) is required so that it can be moved for cleaning underneath.
- 2 This equipment is to be installed with adequate back-flow protection to comply with applicable federal, state and local codes.
- 3 Water pipe connections and fixtures directly connected to a potable water supply shall be sized, installed and maintained in accordance with federal, state and local codes.

The International Plumbing Code of the International Code Council and the Food and Drug Administration (FDA) Food Code manual, direct that this equipment must be installed with adequate back-flow prevention in compliance with federal, state and local codes. For units installed outside of the U.S.A., make sure that the installation is in compliance with the applicable plumbing/sanitation code for your area.

**Installation**

**NOTICE:** Before proceeding, make sure that the counter is capable of supporting at least 81 lbs. (37 kg) to allow for the water boiler at full capacity.

**Leveling**

**WARNING:** Use the leveling legs to level the unit only. Do not use them to adjust the height. Do not extend them higher than necessary.

- 1 Position the water boiler on the counter top. Level it left to right and front to back by turning the bottom of the legs.

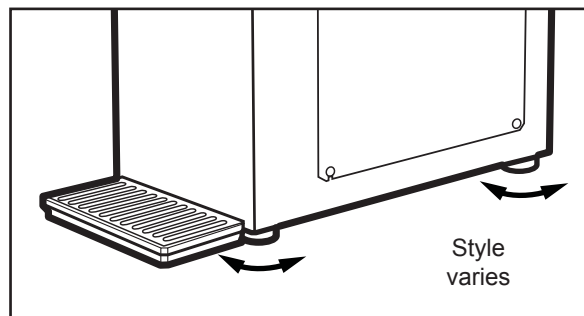

**Connect the Water Supply**

- 2 Flush the water supply line prior to installation to purge air and debris from the water filter and tubing.
- 3 Connect the water supply line to the flare fitting on the back of the unit. Leave the water supply valve closed until the power is connected.

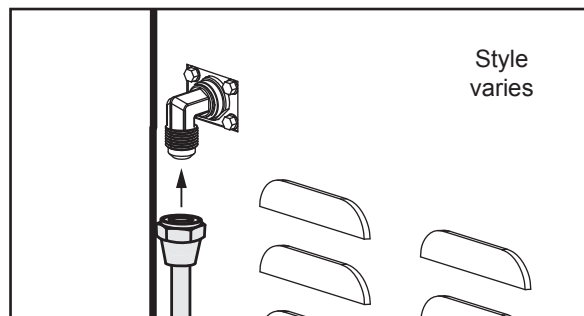

**Connecting the Power Cord (units without power cord installed or units being converted from 120 Volt to 200 - 240 Volt operation)**

**WARNING:** Turn off power to the junction box at the circuit breaker panel before connecting the power cable. Lock out and tag the circuit breaker.

- 4 Remove the top cover from the unit.
- 5 Loosen the strain relief on the back of the unit.
- 6 On units equipped with an existing 120 Volt power cord, disconnect the cord from the power block and remove it. Locate the white jumper wire between the "L2" and "N" terminals on the power block. Disconnect and cap one end of the wire.
- 7 Feed the end of the power cable, through the strain relief and into the unit and connect it to the power block according to the *ELECTRICAL SCHEMATIC*.
- 8 Replace the top cover.
- 9 If applicable, connect the power cable wires to the terminals in the junction box. See the *ELECTRICAL SCHEMATIC* for the power supply requirements.

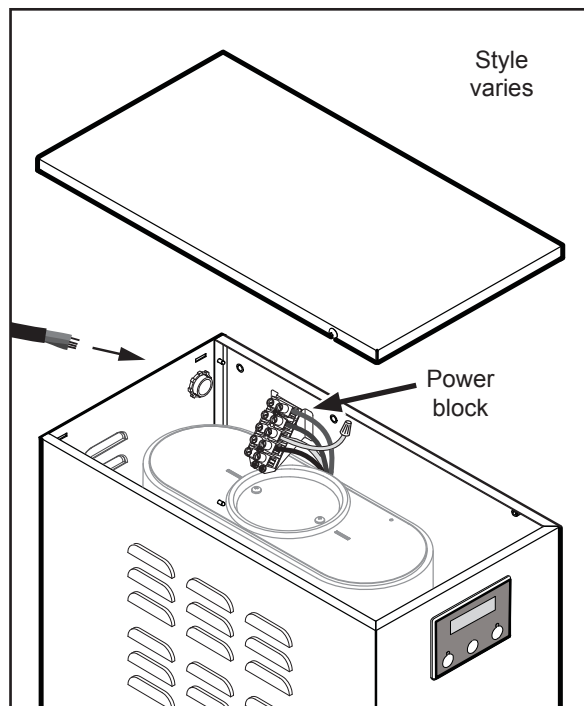

**Connecting the Power Plug (units with pre-installed power cord that will be plugged into a power receptacle)**

- 10 Connect the appropriate type of grounded power plug to the end of the power cord coming from the back of the unit.

**Powering up the Unit**

*Units Operating with a power plug:*



**WARNING:** Connect the power cord only to the appropriate type and size electrical outlet. If the electrical outlet is not compatible with the power cord, have it upgraded by a licensed electrician. Do not modify the power plug. Do not use an extension cord. Do not use a power cord/plug that is damaged.

- 11 Connect the power plug to the appropriate type of electrical outlet.

*All Units:*

- 12 Make sure that the circuit breaker supplying power to the circuit is on.
- 13 Turn on the water supply valve.
- 14 Turn the toggle switch on the back of the unit to the ON position. The water tank will begin to fill.
- 15 Check the water supply line for leaks. While the tank is filling (and whenever the water filter is replaced), you may hear the sounds of air being purged from the filter, tubing and water tank.
- 16 Once the tank is full, the heating elements will turn on (the LEDs on the screen will chase upward). Depending on the incoming water temperature and the electrical specifications, the water tank typically requires 60 to 70 minutes to reach the factory set operating temperature. The bottom left LED will come on when the temperature is within 10°F of the temperature setting on the control panel.



**IMPORTANT:** When operating the unit at higher elevations, reduce the default operating temperature (204°F/96°C) by 2°F for each 1000 feet (300 m) of elevation above 2000 feet (600 m). See **PROGRAMMING GUIDE**.

- 17 Dispense 12 ounces of hot water through the faucet to help purge any remaining air in the lines.

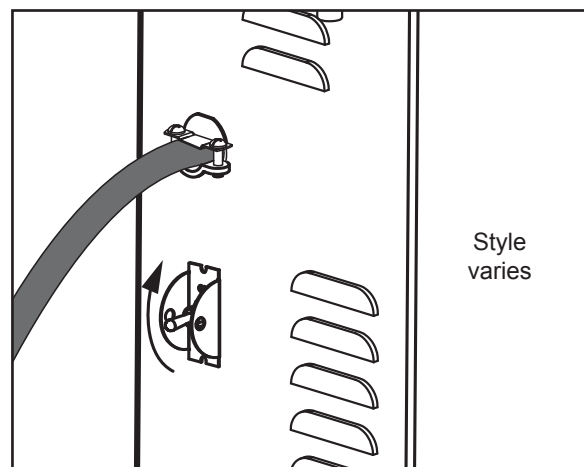
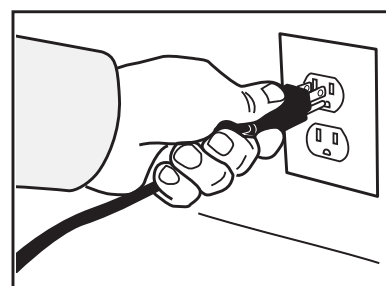
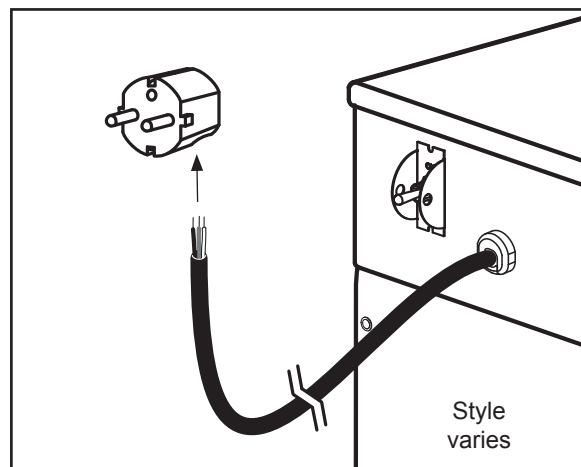





**WARNING: AVOID SCALDING.** This unit dispenses hot water.

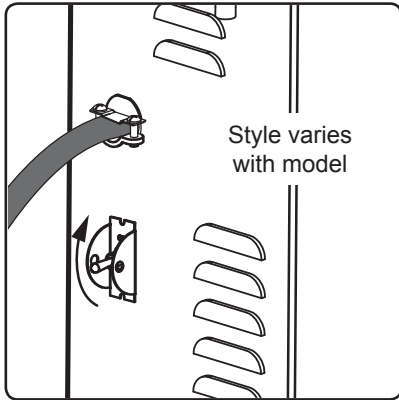

1 The rear toggle switch must be in the ON position. Press the ON/OFF (⏻) button to activate the control panel.

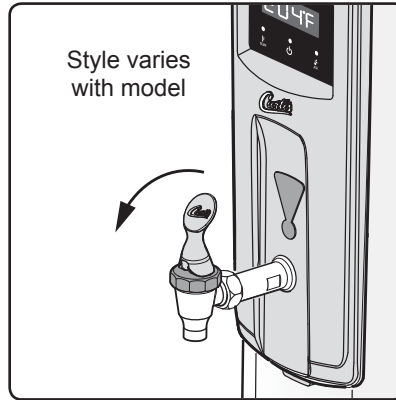

2 Hold a cup under the faucet and pull forward on the handle to dispense.

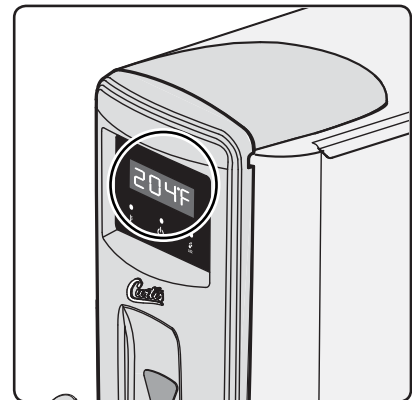

3 The display indicates the current water temperature.\* Or it can be set to say "HOT" when the water reaches serving temperature. See **PROGRAMMING GUIDE** to change the control panel settings.

\* If the water temperature is 10°F below the programmed temperature setting, the light on the display will chase.

**AERATOR**

- The aerator pump will automatically come on every 30 minutes, for five seconds. When aeration is running, the display shows the LED bars chasing from left to right.
- Press the AERATION (AIR) button to manually pump air through the water in the heating tank any time you want. The aerator pump will run as long as you hold down the button.



**Control Panel - WB5GT Series**

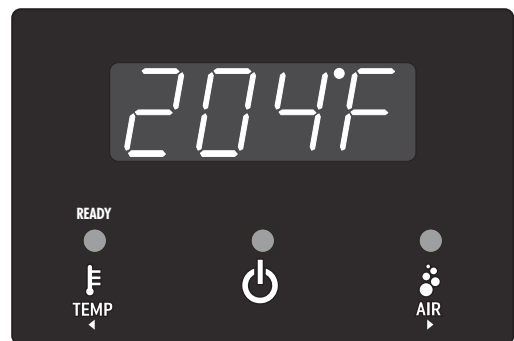

**Control Panel - WB5N Series**



Control Panel - WB5GT Series

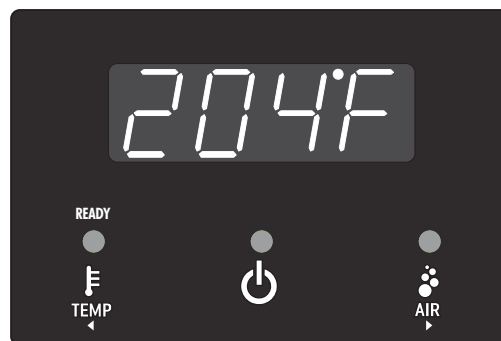

Control Panel - WB5N Series

## Programming Options

### Temperature (default is 204 °F/96 °C)

Press the **TEMP** button for one second to check the control panel water temperature setting. To change the temperature setting, press the **TEMP** button for three seconds, then release, to enter temperature programming mode. The temperature setting range is 140°F to 210°F. Press the left button (◀) or the right button (▶) to lower or raise the temperature. Press **ON/OFF** (⏻) to save and exit.

### HOT - Changing the display to read HOT, instead of the current temperature

Press and hold the **TEMP** button for five seconds. The “F” will start flashing. Continue holding down the **TEMP** button, at the same time, press and hold the **ON/OFF** (⏻) button for five seconds. Release both buttons. The program is now changed and the LED screen will display “HOT”. When “HOT” is displayed, pressing the **TEMP** button for one second will display the current water temperature.

### °F/°C - Changing the display to Celsius (or changing back to Fahrenheit)

**i IMPORTANT:** The Fahrenheit/Celsius setting cannot be changed while the unit is set to display “HOT”. Set the unit to display the temperature first, before changing the temperature scale.

Press and hold down the **TEMP** button for 10 seconds. The temperature reading will change to Celsius (or Fahrenheit). Release the **TEMP** button.

### Energy Saver (default is OFF)

- When energy saver is set to “OFF”, the unit continuously maintains the temperature setting programmed into the control panel.
- When energy saver is set to “ON”, the heating elements shut off four hours after the last dispense.
- When energy saver is set to “140°F”, the unit will begin to maintain the water temperature at 140°F, four hours after the last dispense.
- To return the unit to normal operation after the unit has gone into energy saver mode (ON or 140°F), press one of the control panel buttons or dispense some water.

### To change the energy saver setting

Press and hold both the **ON/OFF** (⏻) and **TEMP** button at the same time for 10 seconds. Use the scroll buttons, ◀ and ▶ buttons to select “OFF”, “ON”, or “140°F”. Press **ON/OFF** (⏻) to save and exit.



**WARNING: HOT SURFACES** - To avoid injury, allow the unit to cool 30 minutes before cleaning.



**NOTICE** - Do not use cleaning liquids, compounds or powders containing chlorine (bleach) or corrosives. These products promote corrosion and will damage the finishes. **USE OF THESE PRODUCTS WILL VOID THE WARRANTY.**

---

### Cleaning The Water Boiler and Dispensing Head - Daily or As Needed

---



**WARNING:** DO NOT immerse the water boiler in water or any other liquid.

---

**The water boiler should be OFF.** Turn the unit off by turning the rear toggle switch to the OFF position. Allow it to cool.

- 1 Wipe exterior surfaces with a soft, damp cloth soaked with a mild detergent solution to remove spills and debris.
- 2 Rinse with a soft cloth soaked with clean water to remove any residual detergent. Then dry.
- 3 If applicable, remove the drip tray screen and rinse it off. Wipe out the interior of the drip tray with a soft, damp cloth. Replace the screen.

### Flushing the Pre-heat Coil (Corinth Models) - Twice a Year

It is recommended that the pre-heat coil be flushed twice a year by a qualified technician according to the instructions in the *Troubleshooting* section.

WB5N Series

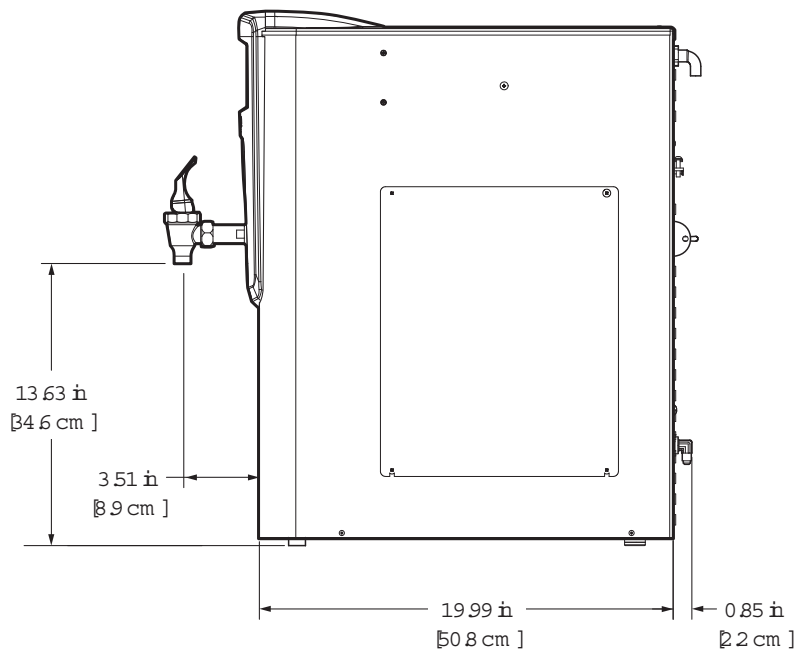
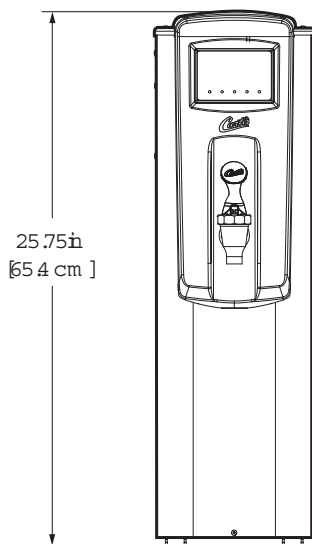
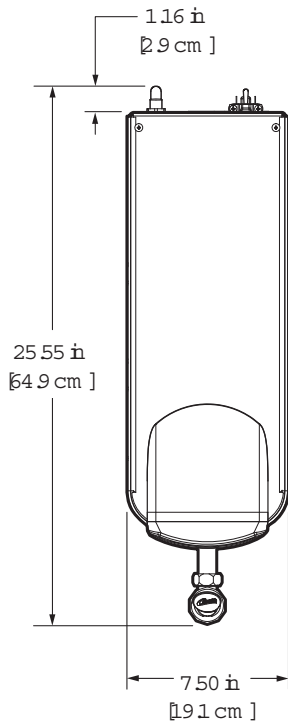

WB5NL Series

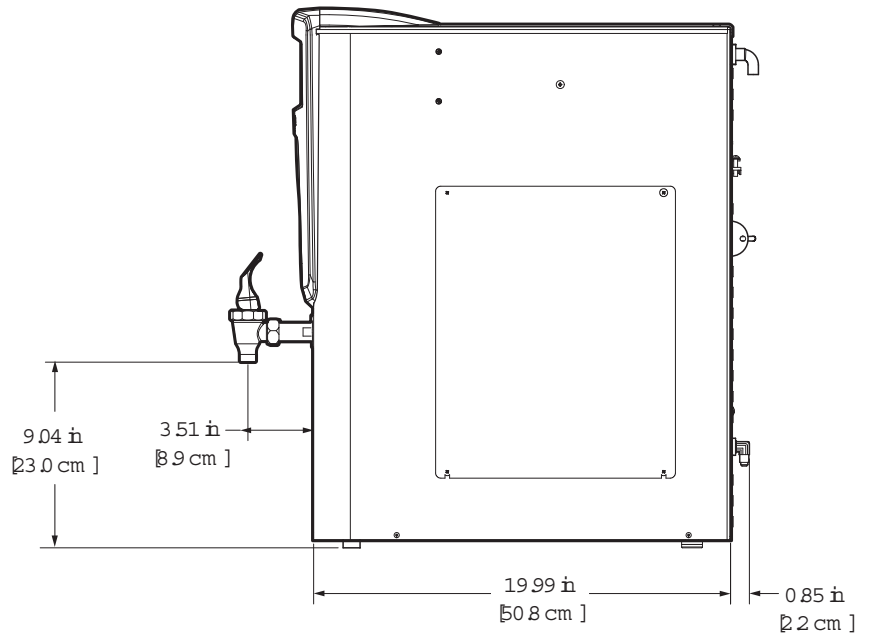
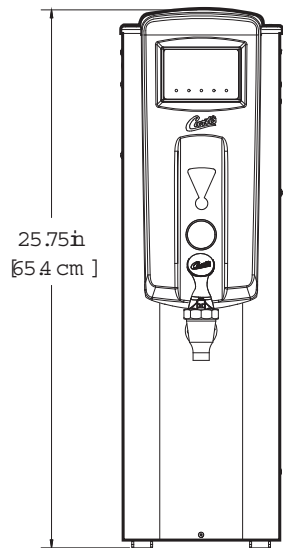
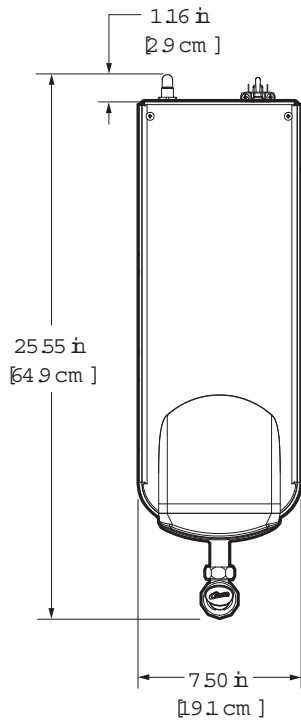

WB5N[L] - Main Chassis - Exploded View

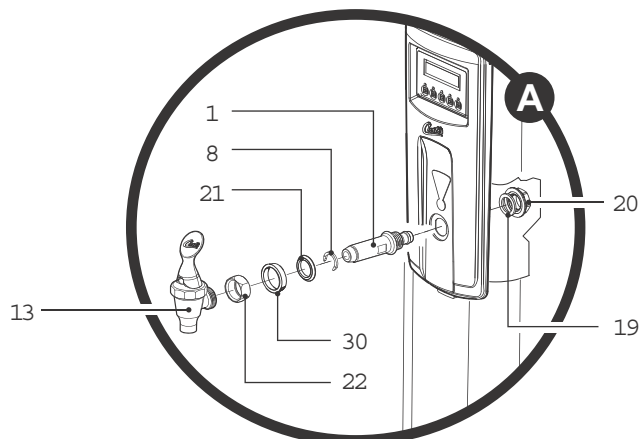

WB5N[B] Series

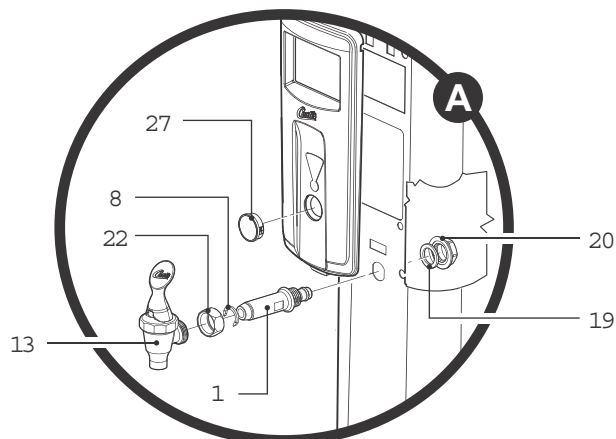

WB5NL[B] Series

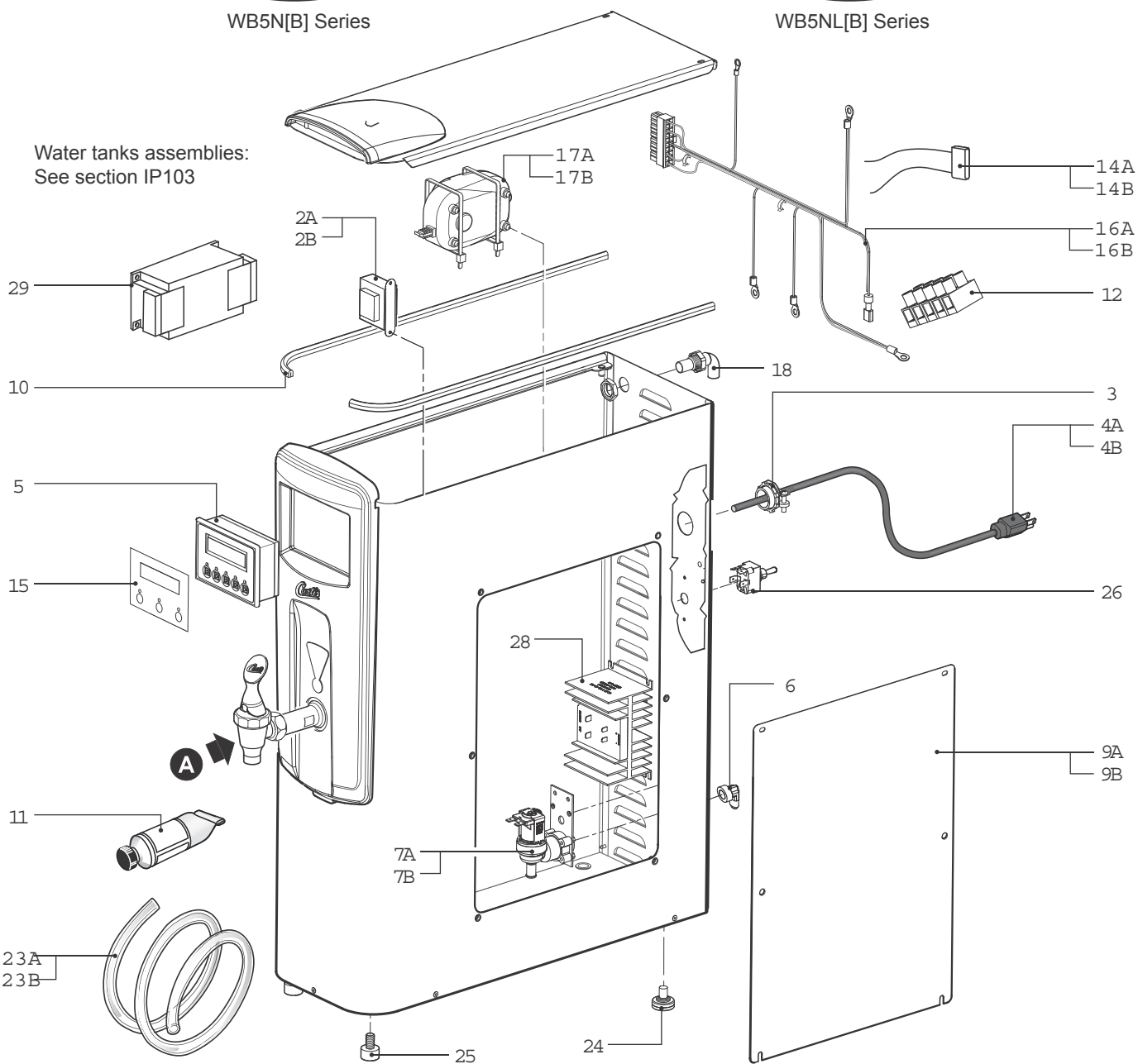

Water tanks assemblies:  
See section IP103

## WB5N - Main Chassis - Parts List

ITEM #	PART #	DESCRIPTION
1	WC-1955	SHANK, FAUCET PLAIN WB5
2A	WC-718 <sup>1,2,3,4</sup>	TRANSFORMER, 120VAC-12VAC
2B	WC-719 <sup>5</sup>	TRANSFORMER, 240/120VAC-12VAC
3	WC-1412	CORD GRIP, 3/4" FOR METAL CORD TO .81"OD
4A	WC-1200 <sup>1,2,3,4</sup>	CORD, 14/3 SJTO 6' BLK W/PLUG
4B	WC-1250 <sup>5</sup>	CORD, 4mm <sup>2</sup> 90°C 49A 450/750V 6 FT LG W/ FERRULES ONE END
5	WC-794K	KIT, MUCM & LABEL WB5N & WB5NL
6	WC-2401-P	ELBOW 3/8 NPT X 1/4 FLARE PLTD
7A	WC-847 <sup>1,2,3,4</sup>	VALVE, INLET 2 GPM 120V 10W GEN USE BROWN BODY
7B	WC-883 <sup>5</sup>	VALVE, INLET 2 GPM 240V 10W
8	WC-1906	"C" RING .917 X .760 X .090 TT-3 TC'S
9A	WC-61549-101 <sup>1,2,5</sup>	COVER, SIDE ACCESS WB5N
9B	WC-61549-101BLK <sup>3,4</sup>	COVER, SIDE ACCESS BLACK WB5N
10	WC-53157-101	TRIM, EDGE GUARD CHROME WB5N/ WB5NL
11	WC-5231	COMPOUND, SILICONE 5 OZ
12	WC-314	POWER BLOCK, 5 STATION
13	WC-1800HW	FAUCET ASSY, RED HANDLE 1-1/32-14 UNS CURTIS
14A	WC-8591 <sup>1,2,3,4</sup>	CAPACITOR, X2 USED ON ALL ADS MODELS
14B	WC-8609 <sup>5</sup>	CAPACITOR, 2.2 UF 250/275 VAC 50/60 ALL ARU'S
15	WC-390034	LABEL, MUCM OVRLAY CONTROL PAN EL WB5N
16A	WC-13046-101 <sup>1,2,3,4</sup>	HARNESS, ASSY 3PH WB5GT19
16B	WC-13046 <sup>5</sup>	HARNESS, ASSY WB5GT30

<sup>1</sup>WB5N, <sup>2</sup>WB5NL, <sup>3</sup>WB5NB, <sup>4</sup>WB5NLB, <sup>5</sup>WB5N30

## Recommended Parts to Stock

ITEM #	PART #	DESCRIPTION
2A	WC-718	TRANSFORMER, 120VAC-12VAC
2B	WC-719	TRANSFORMER, 240/120VAC-12VAC
5	WC-794	CONTROL MODULE, MINI UNIVERSAL 120-220VAC
8	WC-1906	"C" RING .917 X .760 X .090 TT-3 TC'S
7A	WC-847	VALVE, INLET 2 GPM 120V 10W GEN USE BROWN BODY
11	WC-5231	COMPOUND, SILICONE 5 OZ
13	WC-1800HW	FAUCET ASSY, RED HANDLE 1-1/32-14 UNS CURTIS
17A	WC-1048-101	PUMP, ASSY AGITATION WB5GT
17B	WC-1009-101	PUMP, AGITATION 220V W/CAPACITOR & TERMINALS

ITEM #	PART #	DESCRIPTION
17A	WC-1048-101 <sup>1,2,3,4</sup>	PUMP, ASSY AGITATION WB5GT
17B	WC-1009-101 <sup>5</sup>	PUMP, AGITATION 220V W/CAPACITOR & TERMINALS
18	WC-2948	FITTING, TANK OVERFLOW 304SST
19	WC-1813	WASHER, 1-1/8" OD ETHYLENE PROPYLENE RUBBER
20	WC-1939	NUT, FLANGED TLS-2, GEM3, RU'S
21	WC-43157 <sup>1,2,5</sup>	GROMMET, RUBBER .89 ID WB5N WB5NL
22	WC-1903	NUT, UNION SHANK WB-10/WB-10-60/WB-30-12
23A	WC-5310	TUBE, 5/16 ID x 1/8W SILICONE GEN USE
23B	WC-5350	TUBE, 1/2 ID x 1/8W SILICONE GEN USE
24	WC-3518	LEG, GLIDE 3/8"-16 STUD SCREW
25	WC-3503	LEG, 3/8"-16 STUD SCREW BUMPER
26	WC-103	SWITCH, TOGGLE NON-LIT DPST 25A 125/250VAC RESISTIVE
27	WC-43159	PLUG, PLASTIC 1.375" MOUNTING HOLE WB5N & WB5NL
28	WC-8559	RELAY, SOLID STATE, 280Vac MAX W/ INTEGRATED HEAT SINK
29	WC-596K <sup>5</sup>	KIT, NOISE FILTER EMI 250V/30A 1PH
30	WC-43158 <sup>1,2,5</sup>	BUSHING, PLASTIC 1.375" MOUNTING HOLE WB5N & WB5NL

ITEM #	PART #	DESCRIPTION
19	WC-1813	WASHER, 1-1/8" OD ETHYLENE PROPYLENE RUBBER
23A	WC-5310	TUBE, 5/16 ID x 1/8W SILICONE GEN USE
23B	WC-5350	TUBE, 1/2 ID x 1/8W SILICONE GEN USE
24	WC-3518	LEG, GLIDE 3/8"-16 STUD SCREW
25	WC-3503	LEG, 3/8"-16 STUD SCREW BUMPER
26	WC-103	SWITCH, TOGGLE NON-LIT DPST 25A 125/250VAC RESISTIVE
28	WC-8559	RELAY, SOLID STATE, 280Vac MAX W/ INTEGRATED HEAT SINK

WC-54339[-101] - Tank Assembly

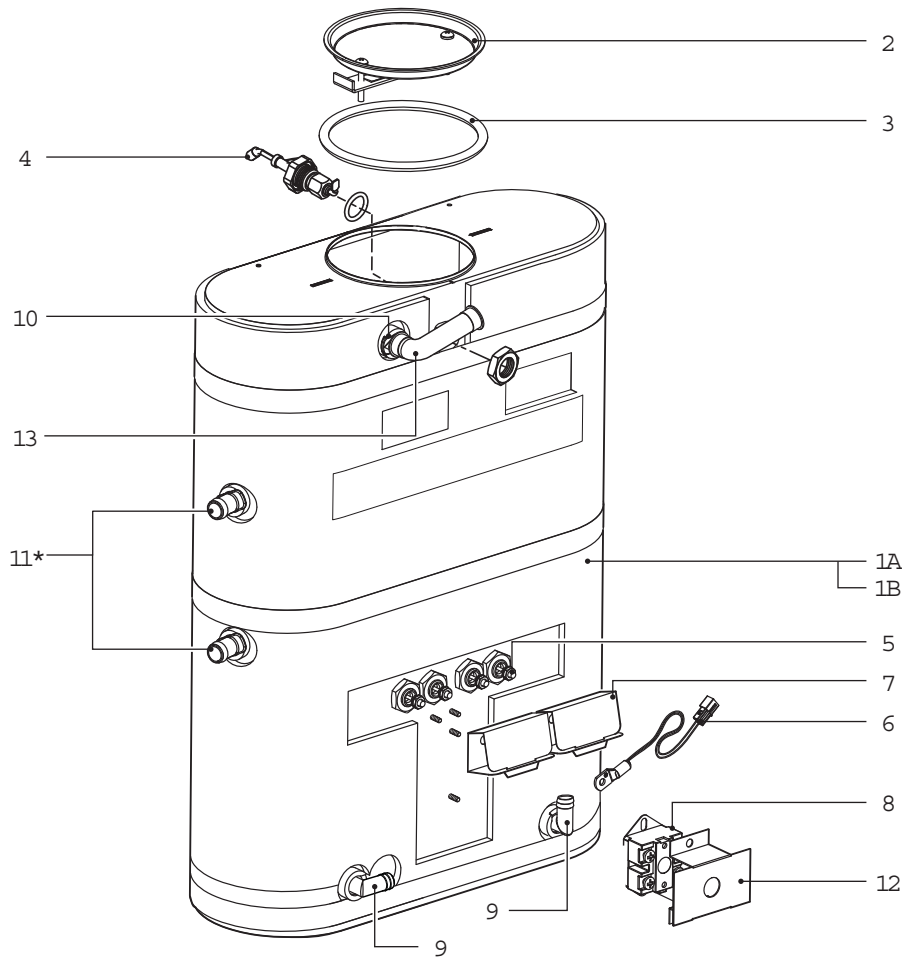

\* Fitting location (hole in side of tank) varies based on part number:  
 WC-54339 = high location,  
 WC-54339-101 = low location.

WC-54339[-101] - Tank Assembly - Parts List

ITEM #	PART #	DESCRIPTION
1A	WC-54339	TANK, ASSY WB5N
1B	WC-54339-101	TANK, ASSY WB5NL
2	WC-37008	LID ASSY, TANK
3	WC-43067	O-RING, 4-1/2" I.D. X Ø.285 SILICONE TANK LID
4	WC-5527-101K	KIT, PROBE, WATER LEVEL WB5N
5	WC-934-04	KIT, ELEMENT HEATING 2.5KW 220V W/JAM NUT & SILICONE WASHERS
6	WC-1438-101	SENSOR, TEMPERATURE TANK
7	WC-4394	GUARD, SHOCK/HEATING ELEMENT FOR SINGLE HEATING ELEMENT

ITEM #	PART #	DESCRIPTION
8	WC-522	THERMOSTAT, HI LIMIT HEATER CONTROL DPST 277V 40A
9	WC-37365	KIT, FITTING TANK INLET
10	WC-37266	KIT, FITTING TANK OVERFLOW
11	WC-37357	KIT, STRAIGHT PLASTIC FITTING AND BUSHING 12MM
12	WC-43055	GUARD, SHOCK RESET THERMOSTAT (WC-522)
13	WC-2471	ELBOW, SILICONE OMEGA

Recommended Parts to Stock

ITEM #	PART #	DESCRIPTION
3	WC-43067	O-RING, 4-1/2" I.D. X Ø.285 SILICONE TANK LID
4	WC-5527-101K	KIT, PROBE, WATER LEVEL WB5N
5	WC-934-04	KIT, ELEMENT HEATING 2.5KW 220V W/JAM NUT & SILICONE WASHERS
6	WC-1438-101	SENSOR, TEMPERATURE TANK
8	WC-522	THERMOSTAT, HI LIMIT HEATER CONTROL DPST 277V 40A

ITEM #	PART #	DESCRIPTION
9	WC-37365	KIT, FITTING TANK INLET
10	WC-37266	KIT, FITTING TANK OVERFLOW
11	WC-37357	KIT, STRAIGHT PLASTIC FITTING AND BUSHING 12MM



WB5GT63000/WB5N Series - Dual Voltage

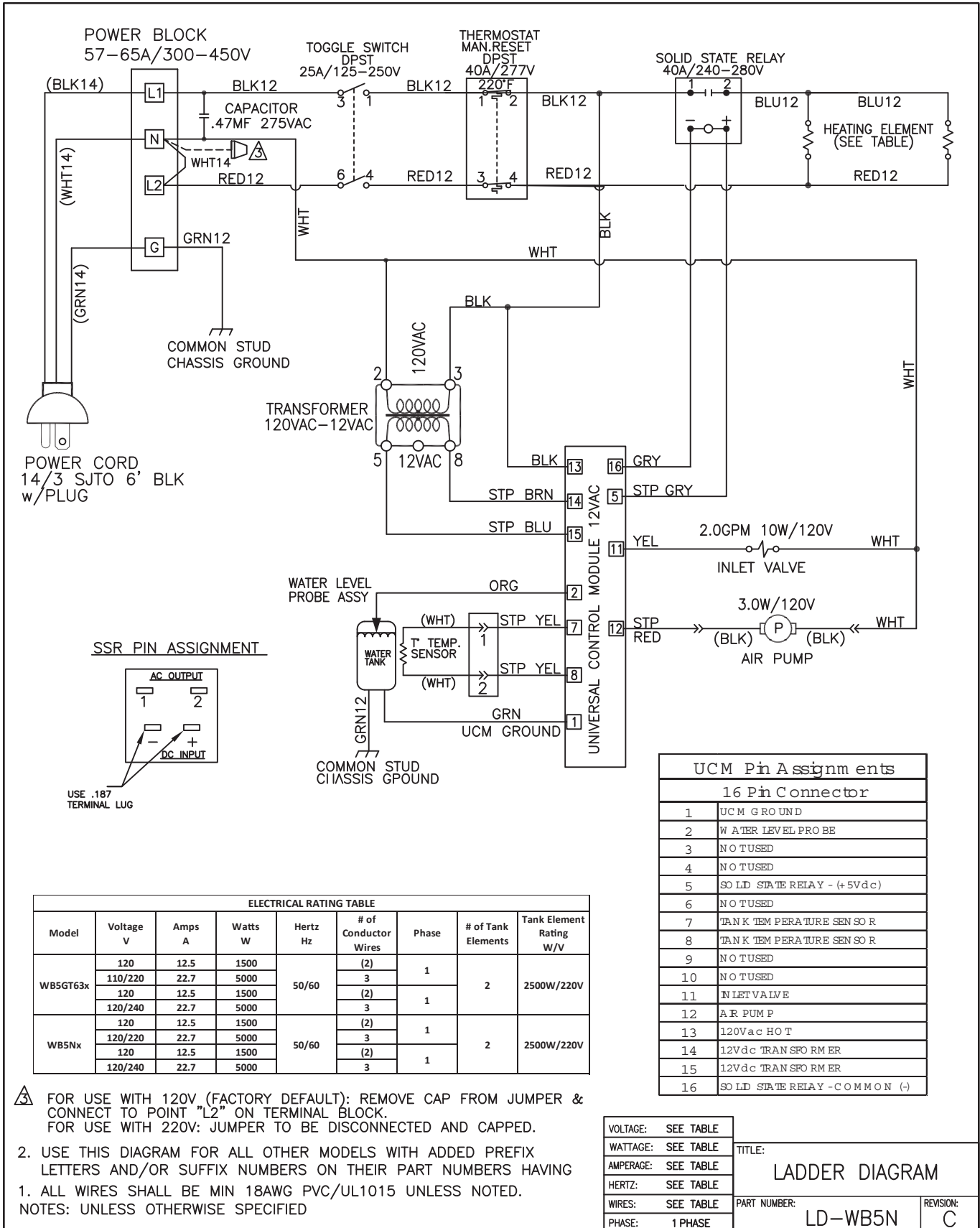

WB5GT/WB5N - Export

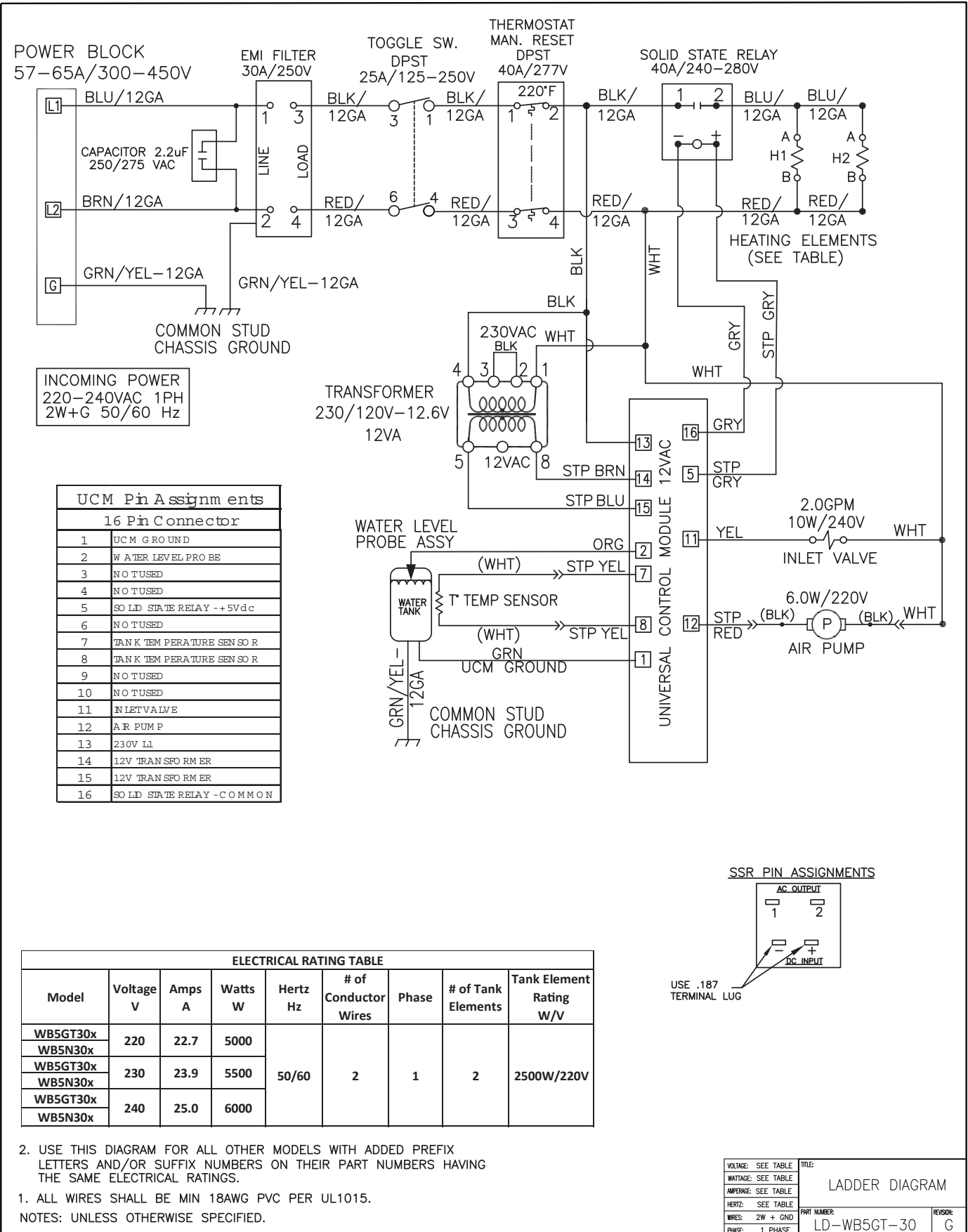

**WARNING:**

**Electric Shock Hazard** - the following procedures are to be performed only by a qualified service technician. Disconnect power when replacing components. Lock out and tag the circuit breaker. Neither Wilbur Curtis Co., Inc. nor the seller can be held responsible for the interpretation of this information, or any liability in connection with its use.

**Scald and Burn Hazard** - keep body parts clear of hot surfaces during troubleshooting.



**IMPORTANT:** If it is necessary to replace the G3 universal control module (UCM), always check the inlet valve for a short and replace the valve as necessary, before replacing the module. See the **Valve Test Procedure** below to test for defective valves.

**Troubleshooting Guidelines**

- If an error message appears on the display, consult the **ERROR CODES** section before troubleshooting.
- A unit that is not level may not function properly. Make sure that the unit is properly leveled before proceeding.
- This troubleshooting guide identifies some, but not all, possible causes for common problems that can occur.
- Use this troubleshooting guide along with the appropriate **ELECTRICAL SCHEMATIC**.

**Valve Test Procedure**

Use a digital multi-meter to measure the resistance of valve coils.

Measure the resistance across the valve coil terminals with the wiring harness disconnected. Reverse the meter leads on the terminals and measure the resistance in the opposite direction. A resistance of less than 100 ohms, in either direction, indicates a shorted coil. The valve must be replaced.

If a shorted coil is not detected, test for an open coil:

- 1 Reconnect the valve terminals to the wiring harness.
- 2 Power up the unit with the appropriate cover removed to allow access to the valve.
- 3 Place a large cup under the water faucet. Drain off water while monitoring the voltage at the inlet valve coil terminals. When voltage is present on the terminals, you should hear the valve click open/closed at the moment power is applied or removed from the terminals. The valve should open any time the water tank is not full. If the valve does not open, replace it. If voltage is not detected, first check the wiring. If the wiring is OK, replace the UCM.

**No Power - Display Not Lit**

- 1 Make sure that the circuit breaker to the circuit supplying power to the unit is not tripped and is turned on.
- 2 On units with a power plug, make sure it is connected to the power receptacle.
- 3 Make sure that the main power toggle switch on the back panel is turned ON.
- 4 Verify that all wires from the power cord are properly connected inside the unit. Check to make sure the wires are not burned/overheated. Loose connections create heat. Check chassis ground.
- 5 Check to make sure power and ground are being supplied to the control module (UCM). If there is power into the UCM, but the display is blank, the UCM is probably bad.
- 6 If there is no power into the UCM, trace the circuit back (using the **ELECTRICAL SCHEMATIC**) to the power cord to find out where power is lost. If there is power into the thermostat reset switch, but not out, see step 7.
- 7 If there is power into the thermostat reset switch, but not out, check to make sure that the water tank is not empty. If the tank is empty, the reset switch has probably opened up due to a low water level, go to **Water Tank Does Not Fill**. If there is water in the tank, but no power out, push in on the reset switch button to see if it restores power. If power is restored, check to make sure that the switch is not opening up at the wrong temperature (the switch should not open up at normal operating water temperatures). If there is still no power through the switch after pushing the button, replace the thermostat reset switch.

### Sensor Error Message (ERR1)

This error indicates a malfunction (open circuit) in the temperature sensor system. Once the malfunction is corrected, the error message must be cleared. To reset the unit and return to normal operation, turn the toggle switch on the back of the unit to the OFF position for 5 seconds, then back ON.

- 1 Check the resistance across the leads of the temperature sensor while it is disconnected from the universal control module (UCM). If an open circuit is measured (resistance above 200 k), replace the sensor.
- 2 If the sensor resistance is less than 200 k check the sensor wires for corrosion and reconnect them to the UCM. Afterward, if the error message comes back after resetting the UCM, replace it

### Water Level Error Message (ERR2)

Water level fill error or overflow. This error message occurs when the inlet valve solenoid has been on too long during initial fill or tank refill. See the **ERROR CODES** section for the maximum times allowed. Also see **Water Tank Overfills**. Once the malfunction is corrected, the error message must be cleared. To reset the unit and return to normal operation, turn the toggle switch on the back of the unit to the OFF position for 5 seconds, then back ON.

### Water Does Not Heat At All

- Check to see if the water level in the tank is in contact with the water level probe. If not, see **Tank Does Not Fill**. The water will not heat unless it is in contact with the probe.
- If the water heats, but is not hot enough, see **Water Not Hot Enough**.
- If the **READY** light is on, but the water is not hot, check the resistance across the leads of the temperature sensor. If the resistance is less than 10 k and the water is not hot, replace the temperature sensor. If the sensor resistance is above 10 k when the water is cool, replace the universal control module (UCM).

If the display is chasing, (unit should be heating), but the water is not hot, follow the steps below. The following steps are performed with the rear toggle switch in the ON position.

- 1 Check for power across the terminals of the heating elements. If power is being supplied, remove the wires and check for an open heating element.
- 2 If there is no power to the elements, trace the circuit back (using the **ELECTRICAL SCHEMATIC**) to the power cord to find out where power is lost. If there is power into the solid state relay(s) (SSRs) but not out, see the following step. On units having two SSRs, be sure to check both.
- 3 If there is power into a SSR, but not out, check for 5 Vdc (nominal) across the + and - pins of the SSR(s). If there is 5 Vdc across the + and - pins of the SSR(s), but no (or low) output voltage at a SSR output terminal, replace the SSR. If 5 Vdc is not being supplied from the UCM, but the display is chasing, check the wiring from the UCM to the SSR(s). If the wiring is OK, replace the UCM.

### Water Not Hot Enough

- 1 If the water heats, but is not hot enough, first check for the correct temperature setting on the control panel. Reprogram as necessary. See **PROGRAMMING GUIDE**.
- 2 If the temperature setting is OK, measure the resistance of the temperature. If the temperature sensor measures below 10 k , but the water is not hot, replace the temperature sensor.

### Water Heats More Slowly Than Usual

- 1 Check for power across the terminals of the heating elements. If power is being supplied, disconnect the heating elements and check for continuity. Replace a heating element if the resistance is too high (nominal resistance is 13 Ohms).
- 2 If there is no power to the heating elements, check the wiring to any element that does not have the proper voltage across it. Also check for corroded connections anywhere between the power cord and the heating elements.

### Water Too Hot (Boiling or Excessive Steaming)



**IMPORTANT:** Before proceeding, make sure that the control panel temperature is adjusted to compensate for higher elevations. The factory setting is 204°F. When operating the unit at higher elevations, reduce this operating temperature by 2°F for each 1000 feet (300 m) of elevation above 2000 feet (600 m).

- 1 If the display is chasing, (unit is heating), first check to make sure that the temperature sensor is attached tightly to the tank and that heat sink compound was used. A properly mounted sensor should have a resistance of around 7 k when the water is hot. If not, replace the sensor.
- 2 Check to see if the universal control module (UCM) constantly has +5 Vdc output (nominal) to the solid state relay (SSR), regardless of the resistance of the temperature sensor. If so, the UCM is probably bad.
- 3 If the UCM is working properly, check for a shorted SSR.

### Aeration (Air) Does Not Work

- 1 If the manual AERATION (AIR) button works, but the unit does not aerate automatically every 30 minutes, the universal control module (UCM) is bad.
- 2 If the aerator pump makes noise when the AERATION (AIR) button is pressed, first check for collapsed, loose or disconnected hoses between the pump and water tank. If all hoses are OK, but the pump makes noise when the button is pressed, check for a defective pump (a pump that does not blow air).
- 3 If the aerator pump does not make noise when the button is pressed, make sure power is being supplied to the pump when the button is pressed. Check for bad wiring, corroded connections or no power output at the UCM. If there is no power out of the UCM when the AERATION (AIR) button is pressed, replace the UCM.

### Water Tank Does Not Fill



**IMPORTANT:** No water or low water in the tank can cause the tank to overheat, resulting in the thermostat reset switch opening. If after correcting a tank fill problem there is no power to the control panel, push the reset switch button.

- 1 Check to make sure the water supply is turned on. Check for a plugged water supply line, clogged water filter or plugged inlet valve.
- 2 If there are no plugs in the water supply line, check for power across the inlet valve terminals. If power is being supplied, but there is no water flow, replace the inlet valve.
- 3 If power is not being supplied to the inlet valve, check the wires between the universal control module (UCM) and the inlet valve. Check for corroded connections.
- 4 If the wiring between the UCM and the inlet valve is OK, but there is no power to the inlet valve, remove the orange wire from the water tank probe. If the water tank starts to fill, replace the water probe. If the water tank does not start to fill, replace the UCM.

### Water Tank Overfills

- 1 Turn the toggle switch on the back of the unit ON and OFF. If water continues to flow when the switch is in both positions, replace the inlet valve.
- 2 If water stops flowing to the water tank when the toggle switch is turned OFF and continues when the switch is turned back ON, remove the orange wire from the water probe on the tank. While power is ON, short the end of the orange wire to the metal surface on the outside of the tank. If the water tank stops filling when the orange wire is shorted to the tank, check for a corroded connection at the water probe.
- 3 If water does not stop flowing when the orange wire is shorted to the tank, check the tank ground connection and the continuity of the orange wire connecting to the universal control module (UCM). If both are OK, replace the UCM.

**System Fault Messages**

An error message will appear on the screen in the event of a malfunction under the following conditions:

- 1 Water level overflow. This error indicates that either there is not enough incoming water flow/pressure or a water overflow condition (unit will stop functioning).
- 2 Break in temperature control circuit..

If any of the errors below appear on the screen, turn off the main power toggle switch and call for service.

ERROR MESSAGE	WARNING DESCRIPTION	CAUSE
ERR1	Fill run error/Overflow	The water inlet valve has either been open for more than 10 minutes on the initial tank fill or has been open for more than 90 seconds in normal operation.
ERR2	Open Probe	Break in the temperature thermistor circuit.

Wilbur Curtis Co., Inc. certifies that its products are free from defects in material and workmanship under normal use. The following limited warranties and conditions apply:

- 3 years, parts and labor, from original date of purchase on digital control boards
- 2 years, parts, from original date of purchase on all other electrical components, fittings and tubing
- 1 year, labor, from original date of purchase on all other electrical components, fittings and tubing

Additionally, Wilbur Curtis Co., Inc. warrants its grinding burrs for forty (40) months from the date of purchase or 40,000 pounds of coffee, whichever comes first. Stainless steel components are warranted for two (2) years from the date of purchase against leaking or pitting. Replacement parts are warranted for ninety (90) days from the date of purchase or for the remainder of the limited warranty period of the equipment in which the component is installed.

All in-warranty service calls must have prior authorization. For authorization, call the Technical Support Department at 800-995-0417. Additional conditions may apply. Go to [www.wilburcurtis.com](http://www.wilburcurtis.com) to view the full product warranty information.

## CONDITIONS & EXCEPTIONS

The warranty covers original equipment at time of purchase only. Wilbur Curtis Co., Inc., assumes no responsibility for substitute replacement parts installed on Curtis equipment that have not been purchased from Wilbur Curtis Co., Inc. Wilbur Curtis Co., Inc. will not accept any responsibility if the following conditions are not met. The warranty does not cover:

- **Adjustments and cleaning:** *The resetting of safety thermostats and circuit breakers, programming and temperature adjustments are the responsibility of the equipment owner. The owner is responsible for proper cleaning and regular maintenance of this equipment.*
- **Replacement of items subject to normal use and wear:** *This shall include, but is not limited to, spray heads, faucets, light bulbs, shear disks, "O" rings, gaskets, silicone tubing, silicone elbows, canister assemblies, whipper chambers and plates, mixing bowls, agitation assemblies and whipper propellers.*

The warranty is void under the following circumstances:

- **Improper operation of equipment:** *The equipment must be used for its designed and intended purpose and function.*
- **Improper installation of equipment:** *This equipment must be installed by a professional technician and must comply with all local electrical, mechanical and plumbing codes.*
- **Improper voltage:** *Equipment must be installed at the voltage stated on the serial plate supplied with this equipment.*
- **Improper water supply:** *This includes, but is not limited to, excessive or low water pressure and inadequate or fluctuating water flow rate.*
- **Damaged in transit:** *Equipment damaged in transit is the responsibility of the freight company and a claim should be made with the carrier.*
- **Abuse or neglect (including failure to periodically clean or remove lime accumulations):** *The manufacturer is not responsible for variation in equipment operation due to excessive lime or local water conditions. The equipment must be maintained according to the manufacturer's recommendations.*

**Repairs and/or Replacements** are subject to Curtis' decision that the workmanship or parts were faulty and the defects showed up under normal use. All labor shall be performed during regular working hours. Overtime charges are the responsibility of the owner. Charges incurred by delays, waiting time, or operating restrictions that hinder the service technician's ability to perform service is the responsibility of the owner of the equipment. This includes institutional and correctional facilities. Wilbur Curtis Co., Inc. will allow up to 100 miles, round trip, per in-warranty service call.

**Return Merchandise Authorization (RMA):** All claims under this warranty must be submitted to the Wilbur Curtis Technical Support Department prior to performing any repair work or return of this equipment to the factory. **All returned equipment must be properly re-packaged in the original carton and received by Curtis within 45 days following the issuance of a RMA.** No units will be accepted if they are damaged in transit due to improper packaging. **NO UNITS OR PARTS WILL BE ACCEPTED WITHOUT A RETURN MERCHANDISE AUTHORIZATION (RMA). THE RMA NUMBER MUST BE MARKED ON THE CARTON OR SHIPPING LABEL. All warranty claims must be submitted within 60 days of service. Invoices will not be processed or accepted without a RMA number. Any defective parts must be returned in order for warranty invoices to be processed and approved.** All in-warranty service calls must be performed by an authorized service agent. Call the Wilbur Curtis Technical Support Department to find an agent near you.